

You will need...

- Gloves to protect your hands
- Shovel
- Eye protection (eg. goggles)
- A spirit level to lay units level
- Drainage material (eg. 12-20mm clean, free draining granular material such as gravel or blue metal)
- Stakes and string
- Agricultural drain (eg. 100mm diameter subsoil pipe)
- Arena™ (Litewall® in SA) units
- Wheelbarrow
- Coarse sand for the levelling pad
- Hammer
- Small broom
- Mechanical plate compactor (optional)

Safety tips

1. Check your equipment
2. Ensure that you read the operating manuals of all the equipment including hired equipment such as mechanical plate compactors and cutting equipment.
3. Always operate equipment according to the manufacturer's instructions and wear the appropriate safety clothing listed by the manufacturer.
4. Check the condition of hand tools such as hammers etc. to make sure they are in safe working order before use.

1. Check with your local council

You should consult with your local council for design regulations prior to the construction of your wall. Councils generally require, and we recommend, that walls greater than 0.5 metres in height and walls located near loading such as a house or a car be designed and certified by a suitably qualified engineer. Boral shall have no responsibility for walls installed other than in accordance with the specifications and recommendations contained in this brochure. Each council has different requirements so it is important you check with your local council before starting.

2. Locate your wall

Mark out the ground where your wall will be located (either by marking with stakes and a string line or by marking a line on the ground with spray paint).

3. Calculate how many blocks are required

- ▶ Measure the proposed wall height and length.
- ▶ To work out the number of blocks just multiply your m² measurement for the wall (wall height x wall length) by the number of Arena™ units per m².
- ▶ It is often worth adding some extra blocks to allow for any mishaps (usually adding an extra 5% will cover you).
- ▶ Don't forget when ordering to specify colour and the type of units required.

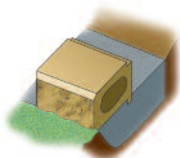

4. Prepare the site

- ▶ Dig a shallow trench approximately 130mm (13cm) deep and 350mm (35cm) wide.
- ▶ Remove any roots and soft earth.

- ▶ Fill the trench with coarse sand or road base, compact and level until it forms a 100mm (10cm) levelling pad.
- ▶ Compact by either manually tamping or using a mechanical plate compactor.

5. Lay the first course

- ▶ Place blocks side by side on the levelling pad using a string line along the back of the units for alignment.

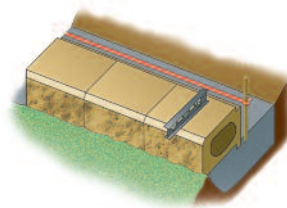

- ▶ Level each unit side to side and front to back using your spirit level.
- ▶ Install the subsoil pipe behind the first course and surround with gravel. Use filter fabric over the subsoil pipe if there are likely to be problems with silt entering the subsoil pipe.

Tips for setting the first course

Spend time on making sure the units are level, otherwise all ensuing courses and ultimately the entire wall will not be level.

6. Backfill and compact

- ▶ Place drainage material (12-20mm sized gravel) to 150mm (15cm) wide behind your first course.
- ▶ Shovel and compact your backfill (existing site soil) behind the drainage material. **Please note:** Backfill should be no higher than the top of the retaining wall (please see Typical Wall Cross Section on page 2).
- ▶ Backfill consisting of heavy clays or organic soils are not recommended due to water holding properties.

Tips for backfilling

Do ensure you place drainage material behind the wall and compact the site soil. If you don't you may find water will build up behind your wall and start to push it over.

7. Additional courses

- ▶ Sweep the top of the previous course clean.
- ▶ Place the next course of Arena™ units in a running bond pattern (ie. with the vertical joints from the first course units halfway across the second course units).
- ▶ Shovel the drainage material and the backfill behind the second course of units (as per step 6).
- ▶ Lay your third course of units and, like previous courses, place drainage material and backfill behind the wall (you don't have to compact the backfill every course but it should be done at least every alternate course ie. in 150mm (15cm) horizontal layers).

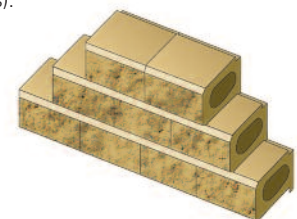

- ▶ Continue stacking units, placing drainage material and compacting backfill until your wall is complete.

Tips for finishing the wall

In areas of vandalism it is recommended that the top units are secured using a construction adhesive such as Liquid Nails. Sealing the constructed Arena™ is recommended to reduce dirt build up and for ease of cleaning.

Typical Wall Cross Section

Please note: Backfill should be no higher than the top of the retaining wall

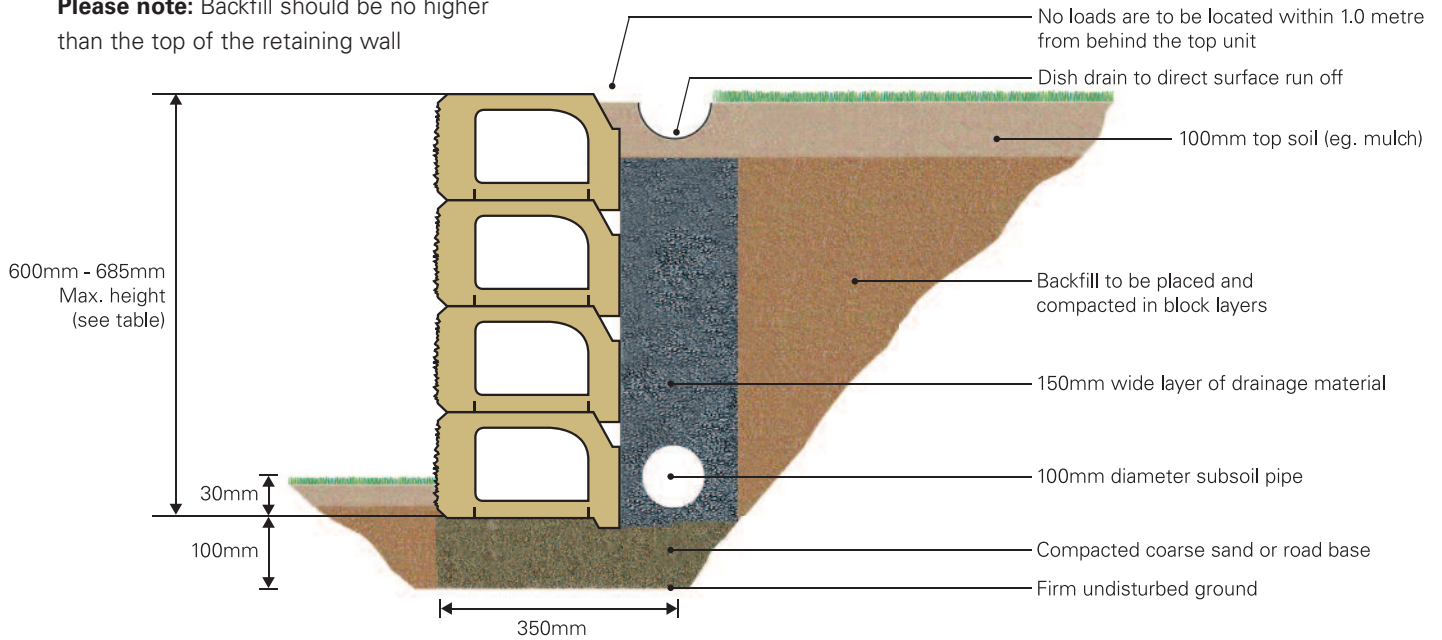

Arena™ Heights

Region	Max. wall height	No. of courses	Backfill type
NSW, SA, QLD	600mm	4	Good
VIC	685mm	5	Good

Please note: Good soils include gravels, sandy gravels and crushed sandstone.

Constructing Corners (NSW, QLD & VIC)

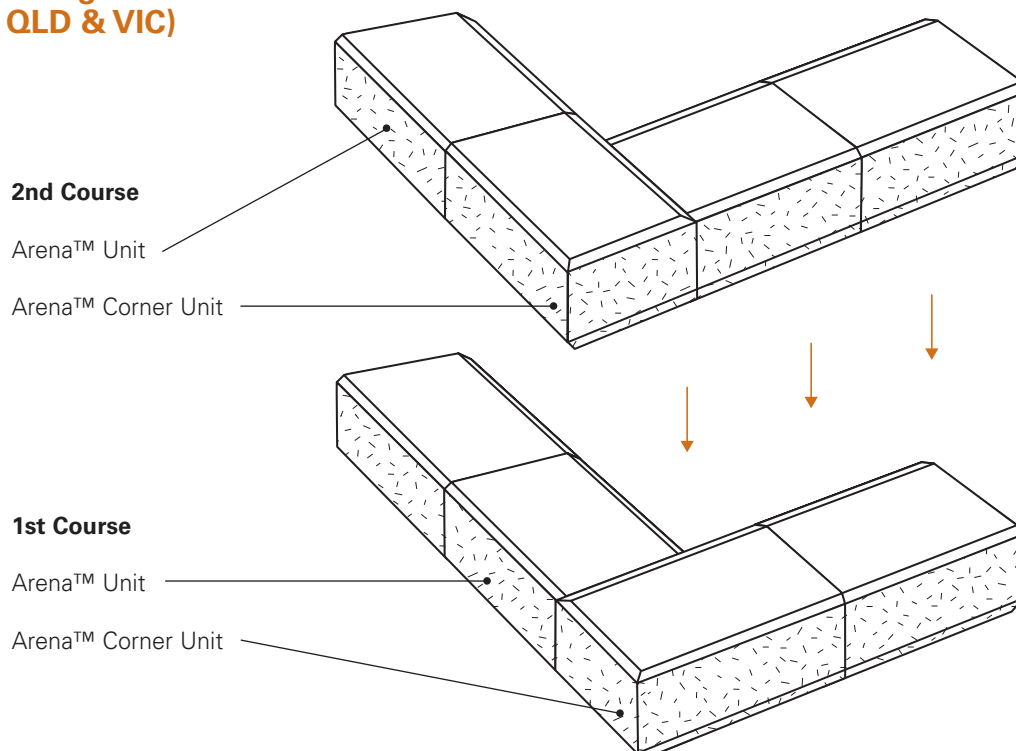



Arena corner unit - NSW, SA & QLD

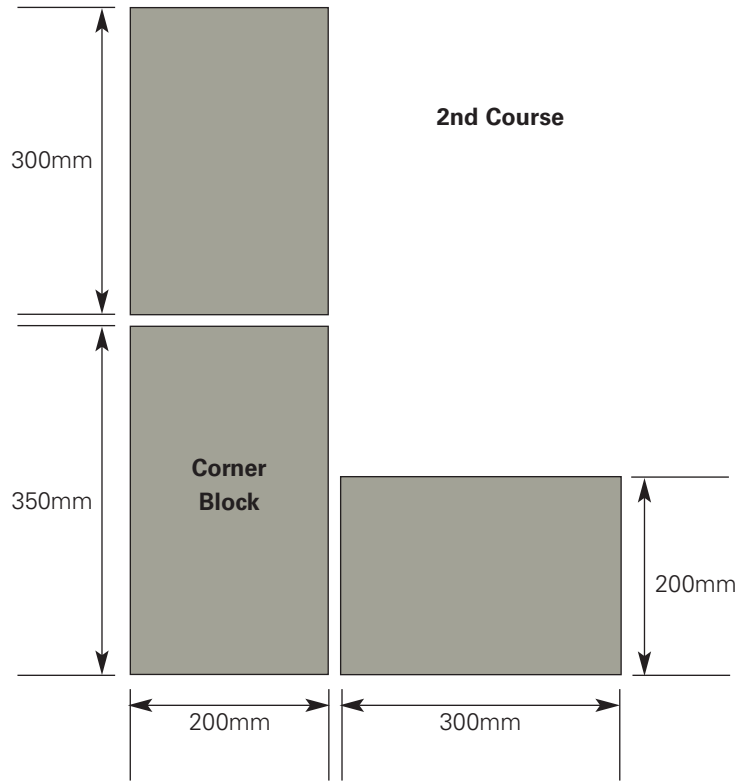
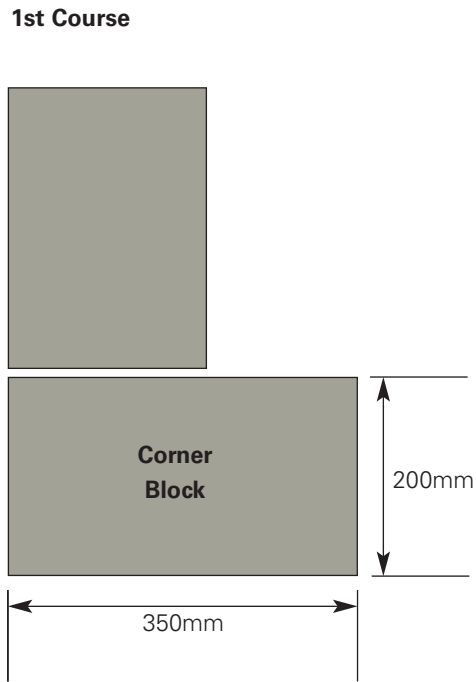

Arena corner unit - VIC

